

COFFEE TABLE

Stock number: 280X-05

Thank you for purchasing this product. Please read the instructions carefully before use to ensure safe and satisfactory operation of this product.

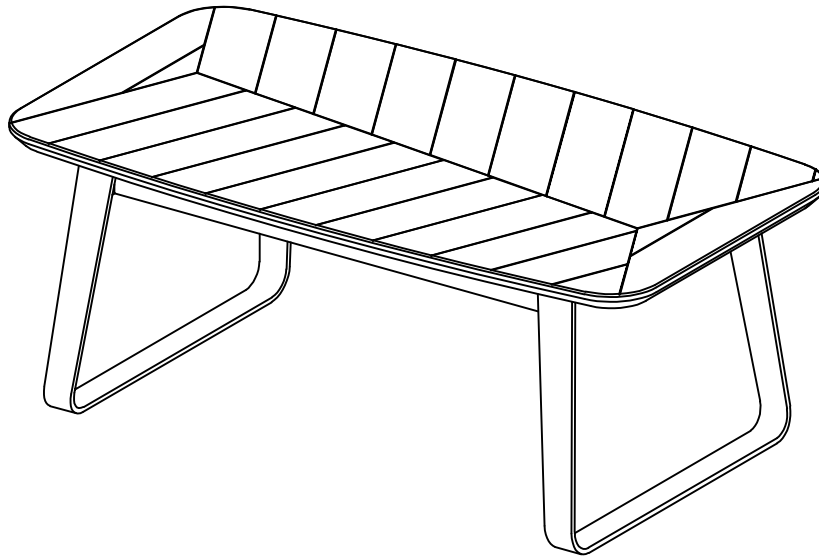

Pre-assembly preparation

Please ensure instructions are read in full before attempting to assemble this product.

Necessary Tools :

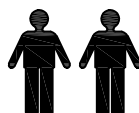

(Included)

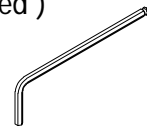

Please check the pack contents before attempting to assemble this product. A full checklist of components is given in this leaflet. If any components are missing, please contact the retailer from whom you bought this product.

This product takes approximately **20 MINUTES** to assemble with **2 PEOPLE**.

All assembly should be performed on a flat, stable, clean and soft surface.





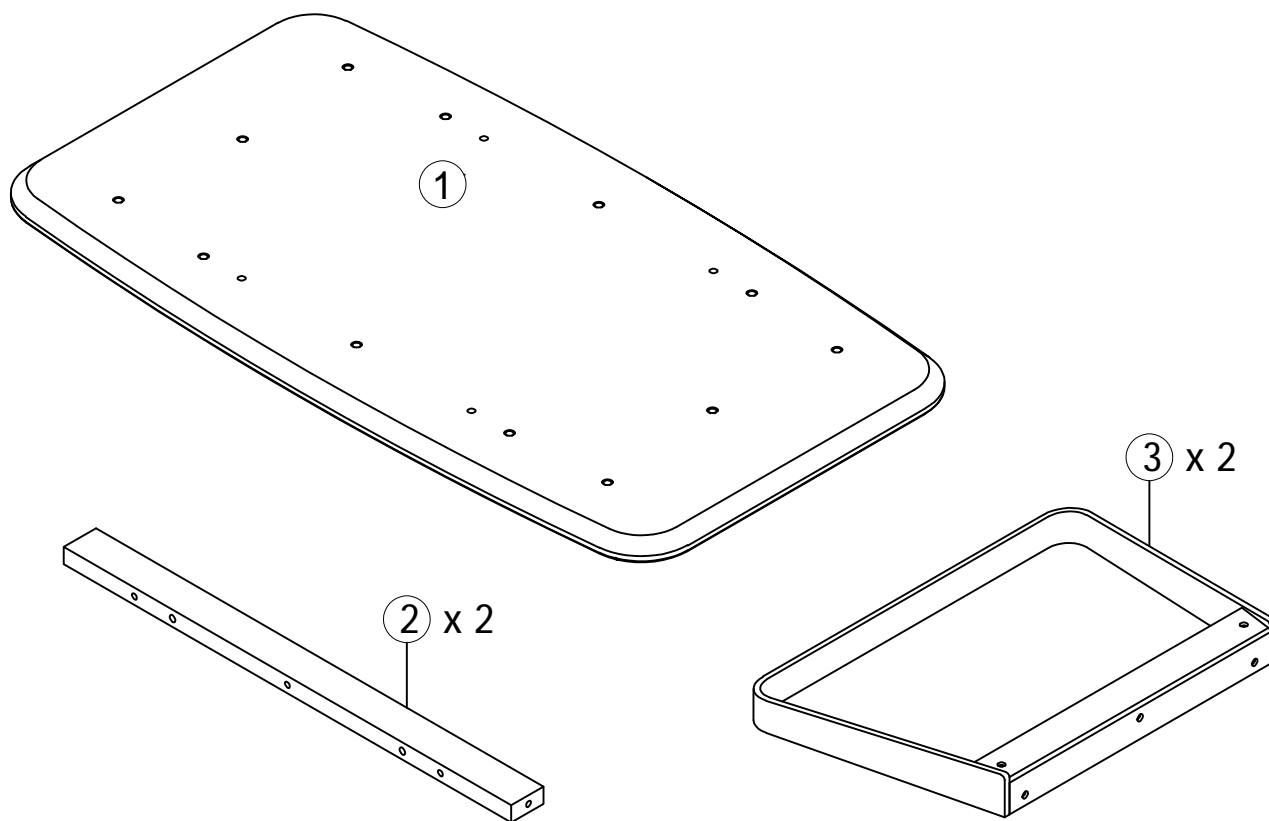

This product is **HEAVY**, it should be assembled as near as possible to the point of use. **TAKE CARE WHEN LIFTING** to avoid personal injury and (or) damage to the product

The fitting pack contains **SMALL ITEMS** which should be **KEPT AWAY FROM YOUNG CHILDREN**.

IMPORTANT: Retain these instructions for future reference.

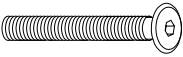

Fittings and parts checklist

Item	Description	Qty.	Item	Description	Qty.
1	Top Panel	x 1	3	Metal leg	x 2
2	Side Apron	x 2			
A	Cross dowel Ø12x30mm	 x 4	E	Lock washer Ø8.4x2mm	 x 6
B	Wooden dowel Ø10x30mm	 x 4	F	Flat washer Ø8.4xØ17x1.6mm	 x 6
C	Short hex head bolt M8x20mm	 x 6	G	Allen key M4x30x110mm	 x 1
D	Long hex head bolt M8x60mm	 x 10			

Step By Step Assembly Instructions

Step 1

- 1.1 : Lay all parts on a flat, stable, clean and soft surface.
- 1.2 : Insert 4x wooden dowels (B) into the pre-drilled holes on side aprons (2) as shown.
- 1.3 : Attach side apron (2) onto top panel (1) as shown. Ensure wooden dowels (B) are aligned correctly with the holes of mating parts before attaching.
- 1.4 : Secure part (2) to part (1) using 6x long hex head bolts (D), 6x lock washers (E) and 6x flat washers (F) as shown. Use an allen key (G) to turn fittings (D) clockwise to fix.

Fitting

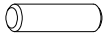

B x 4



D x 6



E x 6



F x 6

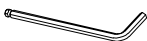

G x 1

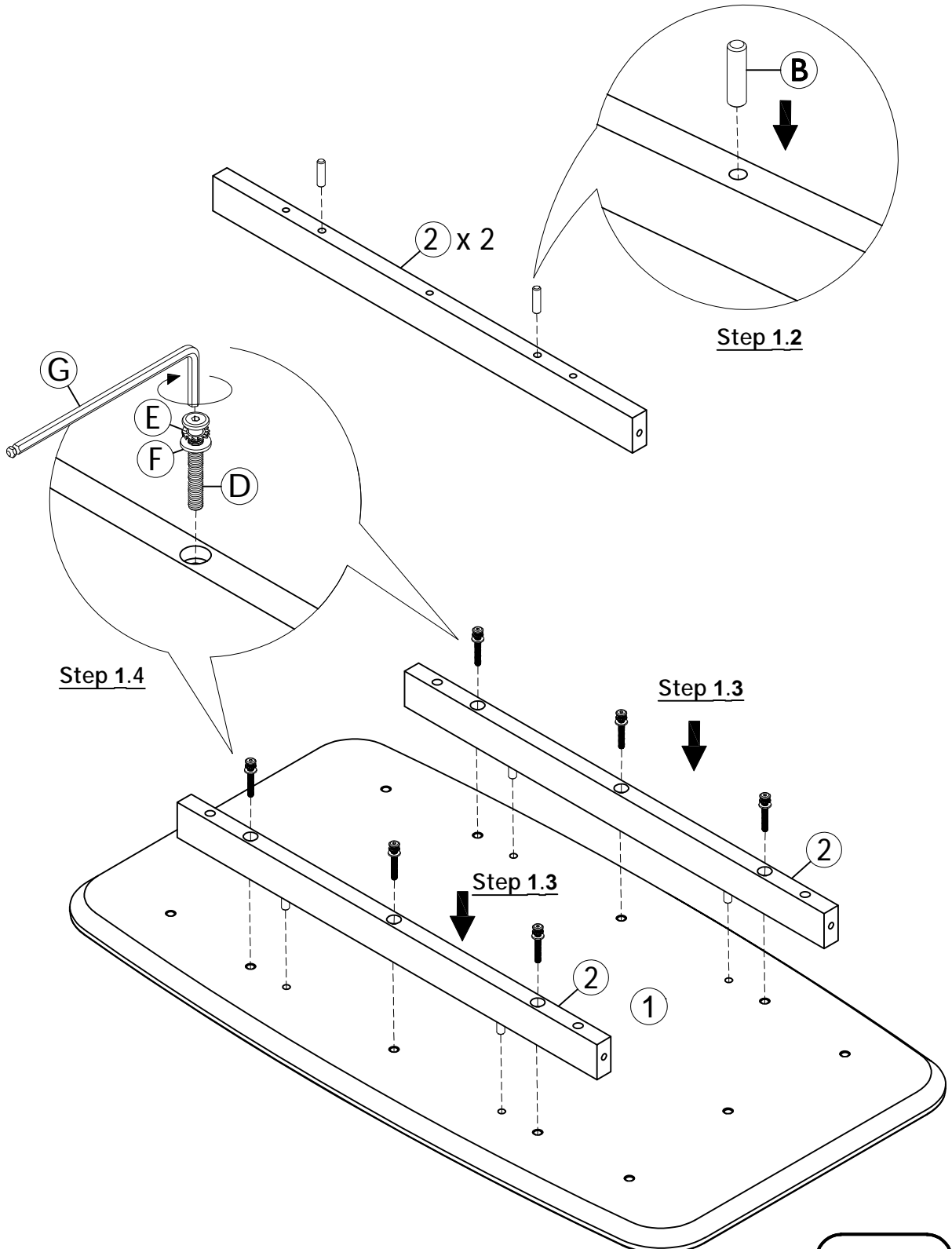

Step By Step Assembly Instructions

- Step 2**
- 2.1 : Insert 4x cross dowels (A) into side apron (2) by placing each fitting (A) into the holes on top of each side apron. Ensure the horizontal marking on each fitting is facing as shown.
- 2.2 : Place metal legs (3) onto side apron (2) & top panel (1) as shown. Ensure the pre-drilled holes on part (3) are aligned correctly with the pre-drilled holes on part (1), (2) before attaching.

Fitting



A x 4

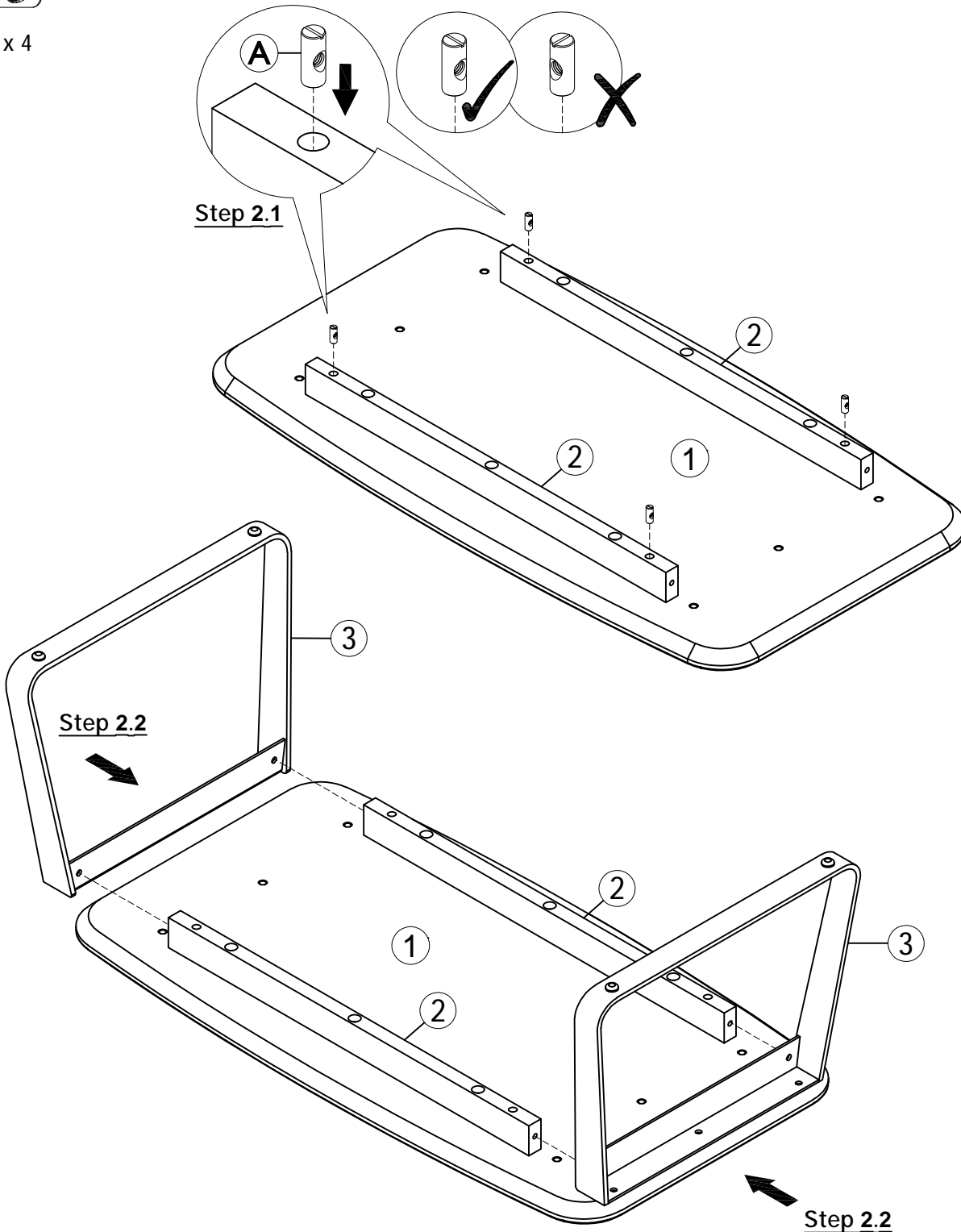

Step By Step Assembly Instructions

- Step 3**
- 3.1 : Secure metal legs (3) to side apron (2) by screwing 4x long hex head bolts (D) into the cross dowels (A) are located on side apron (2) as shown. Use an allen key (G) to turn bolts clockwise to fix. **Do not fully tightening.**
- 3.2 : Secure metal legs (3) to top panel (1) by screwing 6x short hex head bolts (C) into the inset fitting that are located on top panel (1) as shown. Use an allen key (G) to turn bolts clockwise to fix.
- 3.3 : Re-tightening
- 3.4 : Stand the unit upright.

Fitting



D x 4



C x 6



G x 1

